

**REPORT**  
**RESULTS OF**  
**MAGNUMSTONE BLOCK UNIT WITH**  
**SYNTEEN SF35**  
**CONNECTION CAPACITY TESTING**

submitted to

CornerStone Wall Solutions

**CONFIDENTIAL**

Distribution:

2 copies      CornerStone Wall Solutions Inc.  
15400 Morraine Way  
Eden Prairie, Minnesota  
USA 55347-1412

2 copies      Bathurst, Clarabut Geotechnical Testing, Inc.  
1167 Clyde Court, Kingston, Ontario  
K7P 2E4 CANADA

This report shall not be reproduced except in full, without written approval of Bathurst, Clarabut Geotechnical Testing, Inc.

## Introduction

This report gives the results of a connection testing program carried out to evaluate the mechanical/frictional performance of the connection between MagnumStone<sup>®</sup> modular concrete block units and Synteen SF35 geogrid.

The test program was initiated in response to a verbal authorization to proceed from Mr. Vern Dueck of CornerStone Wall Solutions received 23 January 2006.

The tests were carried out at the laboratories of Bathurst, Clarabut Geotechnical Testing, Inc. in Kingston, Ontario, under the supervision of Mr. Peter Clarabut.

## Objectives of test program

The facing-geogrid connection between MagnumStone concrete block units and Synteen SF35 geogrid was investigated using a large-scale connection test apparatus.

The principal objective of the testing was to evaluate the mechanical/frictional performance of these connections. A second objective was to make preliminary recommendations for the selection of long-term tensile connection capacities to be used in the design and analysis of geogrid-reinforced soil wall systems that employ MagnumStone blocks in combination with Synteen SF35 geogrid.

## Materials

MagnumStone blocks are hollow concrete blocks weighing approximately 1350 pounds per unit. The nominal dimensions of the block are 24 inches wide (toe to heel) by 24 inches high by 48 inches long. Construction alignment and wall batter is achieved by means of concrete lugs cast into the bottom surface of the units. The hollow portions within the blocks are typically filled with aggregate. However, the blocks were not infilled with aggregate in this program. The installation arrangement is shown in **Figure 1**. A sketch of the MagnumStone block system and the recommended geogrid connection configuration is shown in **Figure 2**. A photograph of the MagnumStone blocks in the connection frame is shown in **Figure 3**. The blocks used in this series of tests were supplied by D+M Concrete of LaCombe, Alberta and were received at our laboratory on 5 December 2005 and designated as BIC 05-059.

Synteen SF35 is a coated bi-directional grid composed of 100% polyester multifilament yarn with a tensile strength of 3055 lb/ft in the machine direction (based on ASTM D 6637 method of test and reported in the 2005 GFR Specifier's Guide, published December 2004). The specimens used in this series of testing were cut from roll/lot # 26/004/02 received at our laboratory on 9 February 2006.

## Apparatus and general test procedure

The method of test used in this investigation generally follows that reported by Bathurst and Simac (1993) and recommended by the NCMA (Simac et al. 1993) and ASTM D 6638. A

brief description of the apparatus and test methodology is presented here. The test apparatus used to perform the tests is illustrated in **Figure 1**. The test apparatus allows tensile loads of up to 35,000 pounds to be applied to the geogrid while it is confined between two block layers. The facing blocks were laterally restrained and surcharged vertically. Strips of geogrid reinforcement 24 inches wide were attached to a roller clamp and the reinforcement was fed up through the hollow portion of the upper block and wrapped back to a second fixed roller clamp. Two wire-line LVDT(s) were connected to the lower portion of the geogrid to measure geogrid displacement at the back of the block. Wall heights were simulated by placing one block over the interface and applying an additional surcharge load using the vertically-oriented hydraulic jack shown in **Figure 1**. A gum rubber mat was placed over the top block to ensure a uniform distribution of vertical surcharge pressure. The connection force was applied at a constant rate of displacement (i.e. 0.75 inches/minute) to the lower roller clamp using a computer-controlled hydraulic actuator. The load and displacements measured by the actuator and the LVDT(s) were recorded continuously during the test by a microcomputer/data acquisition system. All blocks used in the tests were visually inspected to confirm that they were free of defects. Each test was continued until there was a sustained loss in connection strength due to longitudinal geogrid member failure. Following each test, the blocks were removed and the geogrid examined to confirm failure modes. A virgin specimen of geogrid was used for each test.

The only variable in this series of connection tests was the magnitude of surcharge load.

### Test program

The surcharge loads used in the test program are given in **Table 1**. Also tabulated are the failure loads observed for each test. The measured loads at 3/4 inch displacement have been adjusted by multiplying the measured loads at this displacement by a value of two. This is because only the bottom reinforcement layer moves in the test apparatus and there is a linear relationship between load and displacement. In other words, this correction gives the estimated load on the reinforcement to generate 3/4 inches of displacement if both top and bottom clamps were subjected to the same rate of displacement (rather than the top fixed and the bottom clamp in motion). Finally, the peak and (adjusted) displacement criterion loads have been multiplied by two and summarized in **Table 1**.

### Test results

A summary of tensile loads at peak capacity and after 3/4 inch displacement is given in **Figure 4**.

The peak connection strength between MagnumStone units and Synteen SF35 for walls between 4.5 and 35.0 feet in height ranged between 51 and 61% (assuming equal load carried by top and bottom geogrid layers) of the index tensile strength of 3055 lb/ft in the machine direction (based on ASTM D 6637 method of test and reported in the 2005 GFR Specifier's Guide, published December 2004).

Two repeat tests were performed and the results in **Figure 4** illustrate that there is some variability in connection capacity between nominal identical tests. This variability is less than  $\pm 10\%$  of the mean peak load criterion required by the NCMA (e.g. maximum variability is 5.0%) and is likely the result of small differences in the setting up of the blocks and laying out of the geogrid reinforcement. The trends in data for connection loads at 3/4 inch displacement and at peak capacity have been plotted using linear curves. The reduced connection capacity at lower surcharge loads may be due to the combined effect of lower surcharge pressure and more grid slippage.

There was evidence of slippage of the geogrid within the concrete block-geogrid interface in all tests. Geogrid straining and slippage caused abrasion of longitudinal members as the geogrid was pulled across the concrete surfaces. The amount of slippage was seen to diminish with an increase in wall height.

### **Implications to MagnumStone design and construction with Synteen SF35 geogrid**

The long-term design connection strength in the field must be less than the peak capacity envelope determined in this test series for the same method and quality of construction. The NCMA Segmental Retaining Wall Design Manual (First Edition, 1993) recommends that the design connection capacity at a given surcharge load for a critical wall structure be the lesser of the peak capacity divided by a minimum factor of safety (not less than 1.5) or the capacity based on a 3/4 inch displacement criterion. The *design* curve in **Figure 5** is controlled by the peak connection capacity criterion.

The design capacity envelope illustrated in **Figure 5** should be used with caution. The actual design capacity envelope should be lower if the quality of construction in the field is less than that adopted in this controlled laboratory investigation and/or lower quality concrete is used in the manufacture of the blocks. For example, the interface concrete surfaces should be free of debris before placement of geogrid and blocks in order to minimize abrasion to the geogrid and to maximize the frictional resistance that is developed at the concrete block-geogrid interface.

It is very important that production blocks have uniform dimensions so that there is no stepping at the block joints that can lead to non-uniform frictional resistance at the block-geogrid interface, pinching of the geogrid at the block edges and possibly fracture of the concrete units.

### **Summary of conclusions**

A laboratory testing program was carried out to evaluate the mechanical/frictional connection performance of MagnumStone modular block facing units in combination with Synteen SF35 geogrid. The following conclusions can be drawn:

1. The peak connection strength between MagnumStone units and Synteen SF35 for walls between 4.5 and 35.0 feet in height ranged between 51 and 61% (assuming equal load carried

by top and bottom geogrid layers) of the index tensile strength of 3055 lb/ft in the machine direction (based on ASTM D 6637 method of test and reported in the 2005 GFR Specifier's Guide, published December 2004).

2. The trends in data for connection loads at 3/4 inch displacement and peak capacity have been plotted using linear curves.
3. Care must be taken during the installation of MagnumStone units in order to prevent accumulation of soil and rock debris at the concrete block-geogrid interface surfaces. This debris may significantly reduce the capacity of the MagnumStone facing unit-geogrid system.
4. The design envelope in **Figure 5** is based on an interpretation of test data as recommended in the NCMA Segmental Retaining Wall Design Manual (First Edition, 1993). The choice of design connection strengths may vary from site to site and quality of construction in the field may require lower design values than those taken from **Figure 5**.



P. Clarabut



R. J. Bathurst, Ph.D., P. Eng.

## REFERENCES

ASTM D 6638-01. Standard Test Method for Determining Connection Strength between Geosynthetic Reinforcement and Segmental Concrete Units (Modular Concrete Blocks), American Society for Testing and Materials, West Conshohocken, PA 19428-2958 USA.

Bathurst, R.J. and Simac, M.R., 1993. Laboratory Testing of Modular Unit/Geogrid Facing Connections, *ASTM Symposium on Geosynthetic Soil Reinforcement Testing Procedures*, San Antonio, 19 January 1993.

Simac, M.R., Bathurst, R.J., Berg, R.R. and Lothspeich, S.E., 1993. *NCMA Segmental Retaining Wall Design Manual (First Edition)*, National Concrete Masonry Association, 2302 Horse Pen Road, Herndon, VA 22071-3406.

**Table 1:**

Test program:

Connection capacity results for MagnumStone segmental concrete block units based on testing with a single block (without fill) and Synteen SF35

| Test number | approximate wall height (feet) | approximate number of blocks | normal load (lb/ft) | connection strength at 3/4 inch displacement (lb/ft) | peak connection strength (lb/ft) |
|-------------|--------------------------------|------------------------------|---------------------|--|----------------------------------|
| 1           | 16.7                           | 8.3                          | 2308                | 1190   | 1553                             |
| 2           | 4.5                            | 2.3                          | 626                 | 1157   | 1586                             |
| 3           | 10.6                           | 5.3                          | 1464                | 1343   | 1800                             |
| 4           | 16.6                           | 8.3                          | 2302                | 1440   | 1676                             |
| 5           | 22.9                           | 11.4                         | 3169                | 1420   | 1643                             |
| 6           | 28.9                           | 14.4                         | 3995                | 1575   | 1868                             |
| 7           | 16.7                           | 8.3                          | 2308                | 1229   | 1676                             |
| 8           | 35.0                           | 17.5                         | 4845                | 1532   | 1856                             |

Note: Assuming equal load in top and bottom layers which corresponds to 100% geogrid coverage in a field installation using a staggered block arrangement (running bond).

LEGEND

- |   |                            |    |                    |    |  |
|---|----------------------------|----|--------------------|----|--|
| 1 | MagnumStone Block          | 6  | guide rail         | 11 | wire-line LVDT                         |
| 2 | Synteen SF35               | 7  | LVDT clamp         | 12 | computer controlled hydraulic actuator |
| 3 | loading platen             | 8  | surcharge actuator |    |  |
| 4 | roller clamp               | 9  | loading frame      |    |  |
| 5 | lateral restraining system | 10 | spacers            |    |  |

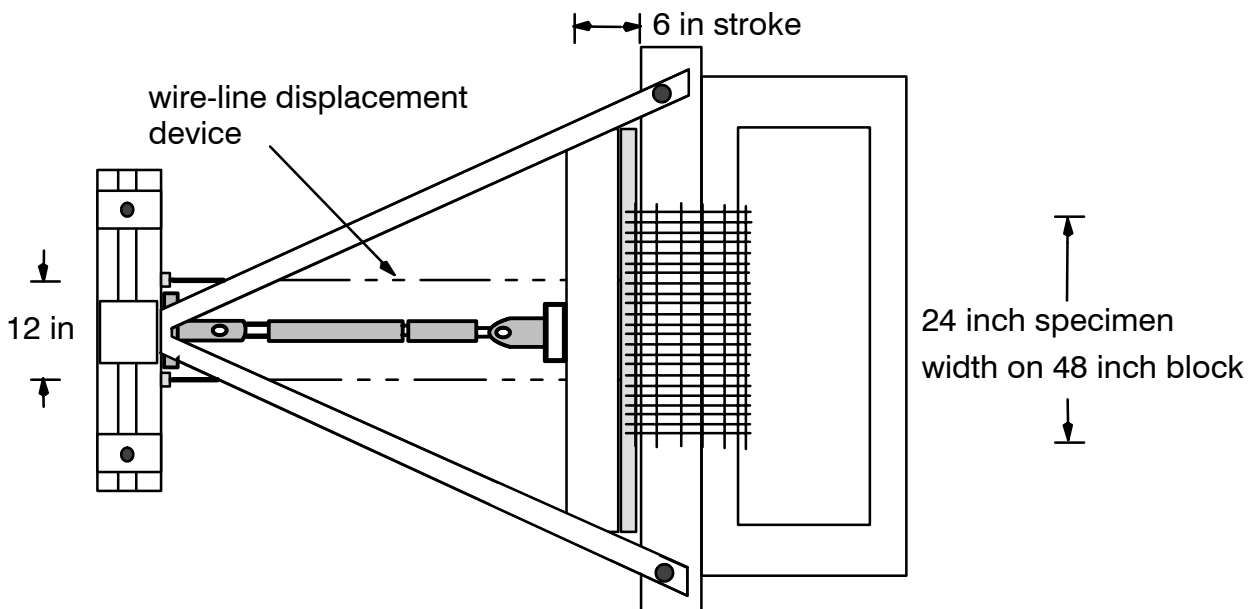
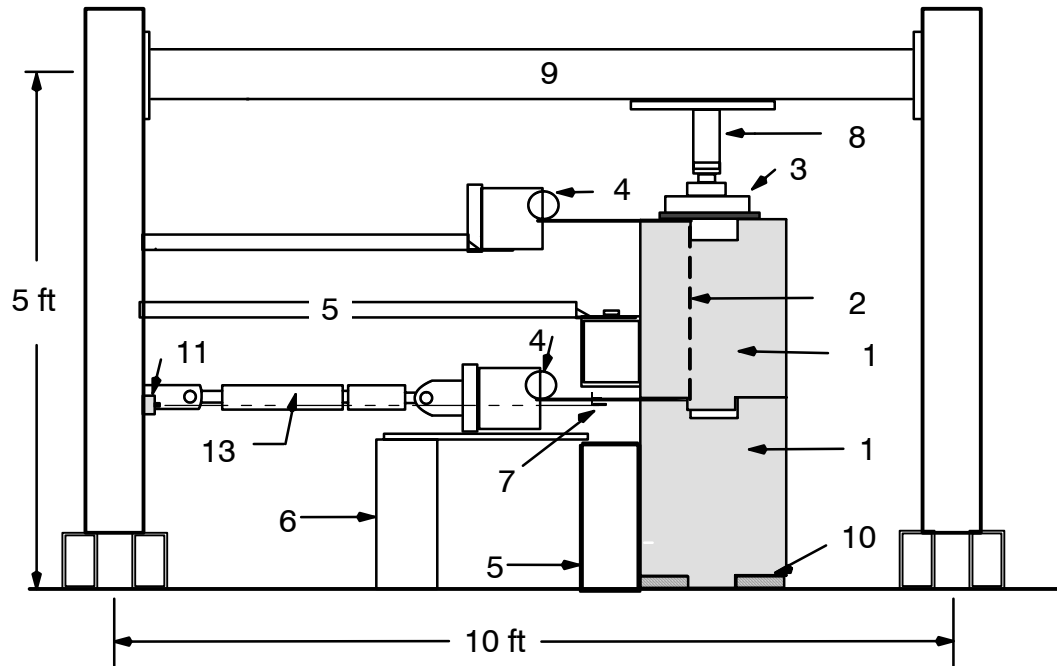

Figure 1: Schematic of connection test apparatus showing MagnumStone block units and Synteen SF35 geogrid

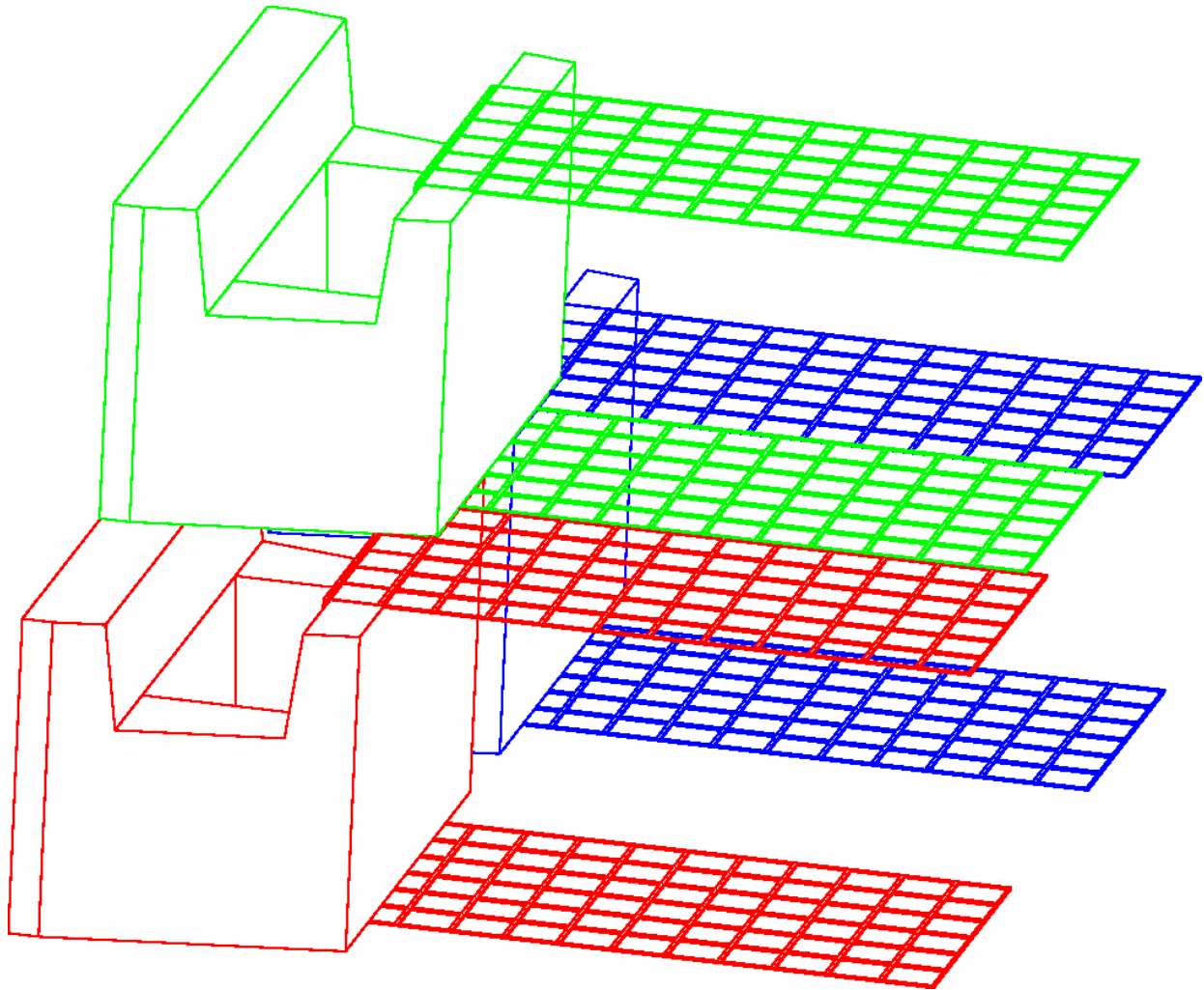

Figure 2: Sketch of the MagnumStone blocks showing the recommended geogrid connection arrangement.





Figure 3: Photograph of the MagnumStone blocks in the connection frame

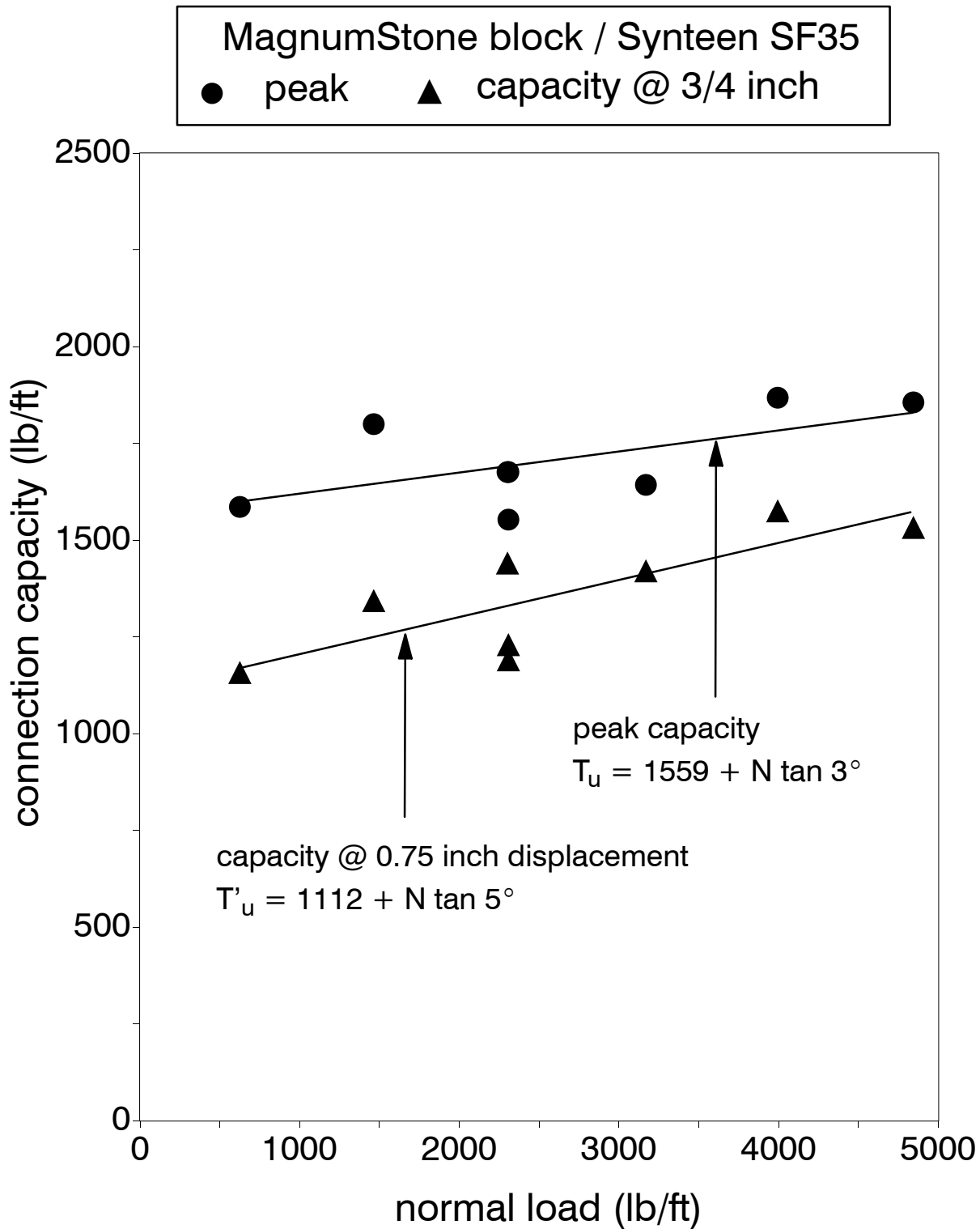

Figure 4: MagnumStone block / Synteen SF35 connection capacity test results

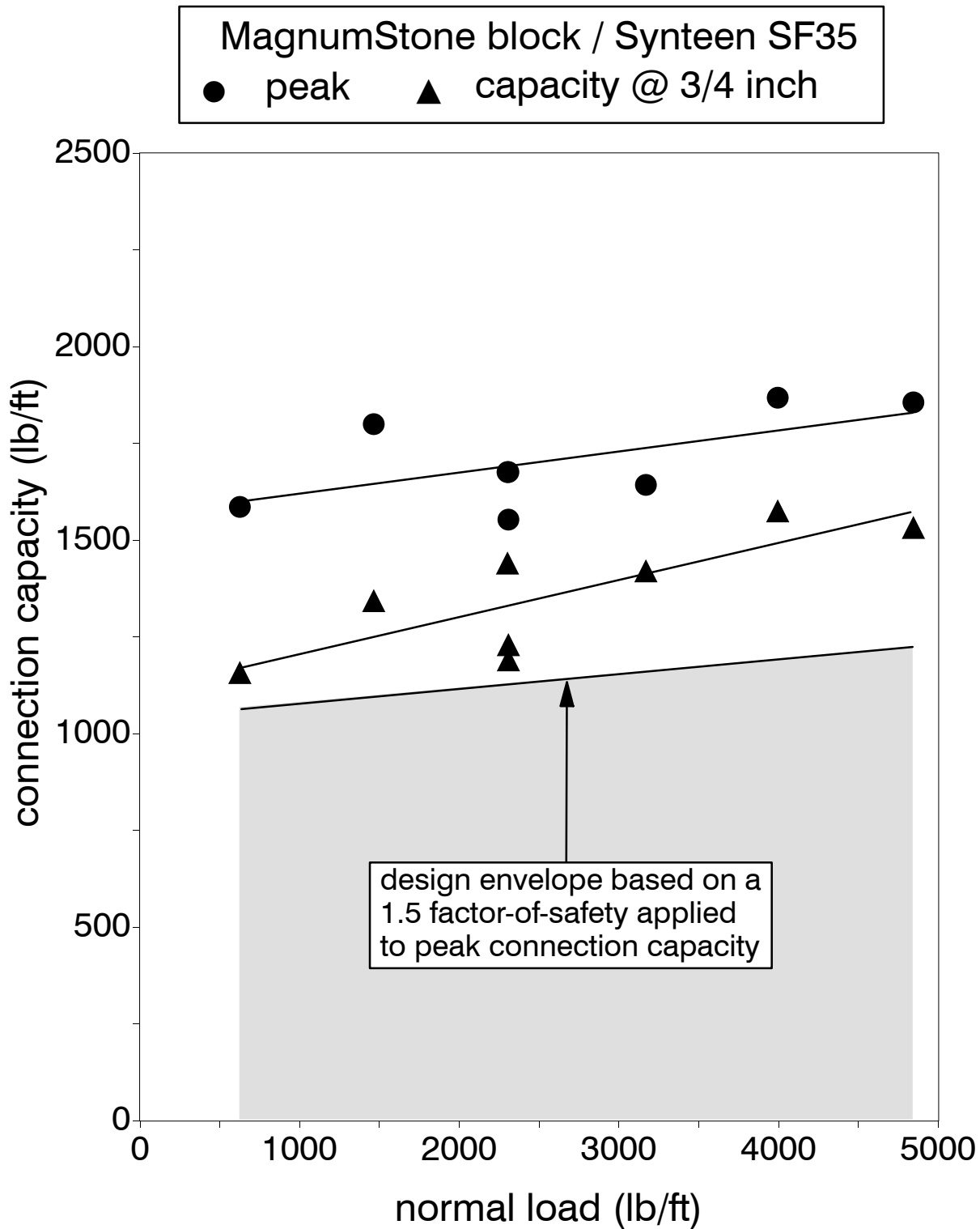

Figure 5: Preliminary design capacity envelope for MagnumStone block / Synteen SF35 geogrid combination